

MAT385 Final, Fall 2002

Name:

Directions:

- All problems are equally weighted. **You must skip one of problems 1-6, but you may not skip problems 7-11!** Write “SKIP” clearly on this problem.
- Show your work! Answers without justification will likely result in few points. Your written work also allows me the option of giving you partial credit in the event of an incorrect final answer (but good reasoning).
- Indicate clearly your answer to each problem (e.g., put a box around it).
- **Good luck!**

Problem 1. True or False?

1. () If the dog eats my exam, then I'll get an F;
if I get an F, then my family will not be pleased.
My family is not pleased. Therefore the dog ate my exam.
2. () The following is an example of a wff: $A \vee C \wedge B$
3. () The rational numbers and natural numbers are not the same size as sets.
4. () Floyd's algorithm is designed to find the optimal traversal of a graph.
5. () The aim of a proof by contradiction is to produce a counter-example.

Problem 2. Consider the following four graphs:

A

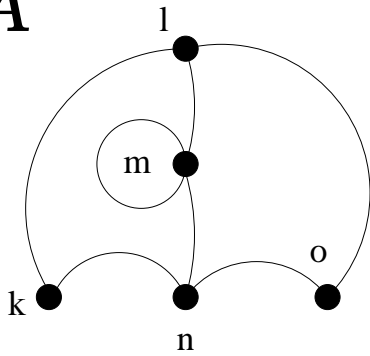

B

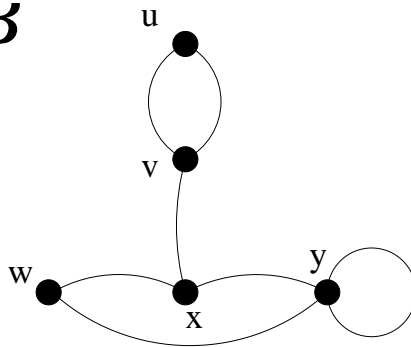

C

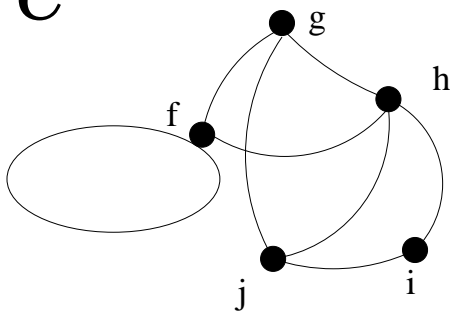

D

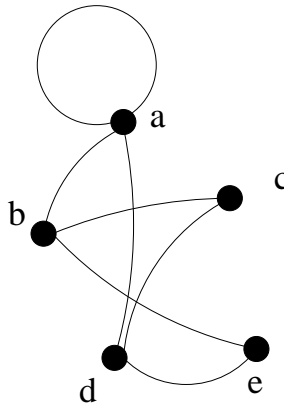

1. Which of these graphs are isomorphic to each other, and which are unique? Give reasons for your classification!

2. Which of the graphs admit Euler paths and which admit Hamiltonian circuits?

Problem 3. Using predicate logic, either prove that the following argument is valid, or give an interpretation in which it is false:

$$(\exists x)[P(x) \rightarrow Q(x)] \wedge (\forall y)[Q(y) \rightarrow R(y)] \wedge (\forall x)P(x) \rightarrow (\exists x)R(x)$$

Problem 4. Set Theory stuff!

1. Part A (5 points): Describe each of the following sets:

(a) $\{x \mid x \in \mathbb{N} \text{ and } (\exists q)(q \in \{-1, 2, 3\} \text{ and } x = 2q)\}$

(b) $\{x \mid x \in \mathbb{N} \text{ and } (\exists y)(\exists z)(y \in \{0, 1\} \text{ and } z \in \{3, 4\} \text{ and } y < x < z)\}$

2. Part B (5 points):

(a) What can be said about A if $\wp(A) = \{\emptyset, \{\{a\}\}\}$?

(b) Is the following a binary operation on the set of natural numbers \mathbb{N} ? Why or why not?

$$x \circ y = x + 1$$

Problem 5.

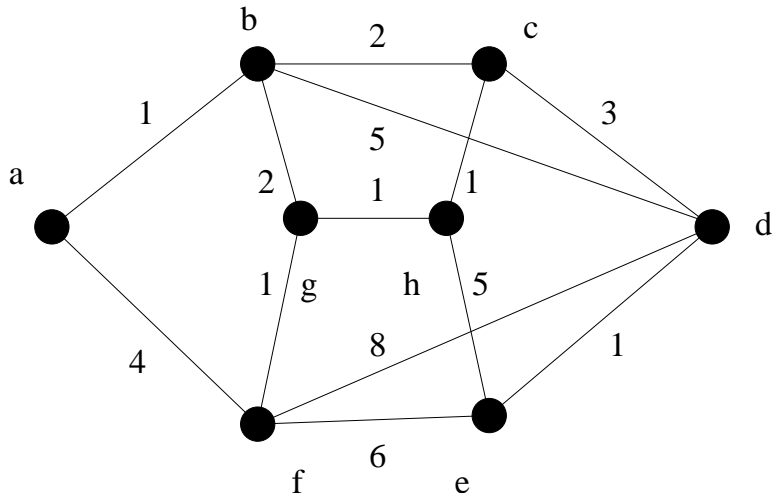

1. (8 points) Use Dijkstra's algorithm (in all its glory) to find the shortest distance from node c to f . Make sure to show the details as you step through the algorithm.

2. (2 points) Is this graph planar? If so, demonstrate; if not, explain why not.

Problem 6. Consider the equation relating Fibonacci numbers

$$F(n + 3) = 2F(n + 1) + F(n)$$

for $n \geq 1$.

1. Prove this by the definition of the Fibonacci numbers.

2. Prove it by induction.

Problem 7. Consider the set S of all binary strings containing zeros either

- entirely in adjacent pairs, or
- always separated by at least 1 one.

1. (3 points) Represent set S as a regular expression.

2. (7 points) Construct a finite-state machine (whose input and output alphabets are the set $\{0, 1\}$) to recognize the regular set S . Try to be neat!

Problem 8. Write a Boolean expression and a truth function for the following logic network:

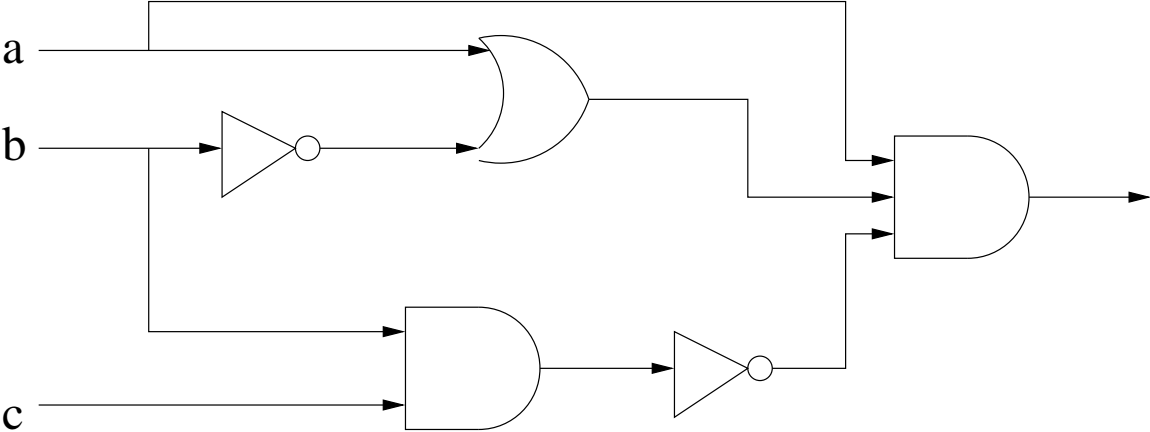

Problem 9. Use the Quine-McCluskey procedure to find the minimal sum-of-products form for the Boolean expression

$$x_1x_2'x_3x_4' + x_1'x_2'x_3x_4 + x_1'x_2x_3x_4 + x_1'x_2'x_3'x_4' + x_1'x_2x_3'x_4' + x_1'x_2'x_3'x_4$$

Problem 10. Consider the following truth function:

| x_1 | x_2 | x_3 | x_4 | $f(x_1, x_2, x_3, x_4)$ |
|-------|-------|-------|-------|-------------------------|
| 1 | 1 | 1 | 1 | 1 |
| 1 | 1 | 1 | 0 | 1 |
| 1 | 1 | 0 | 1 | 1 |
| 1 | 1 | 0 | 0 | 0 |
| 1 | 0 | 1 | 1 | 1 |
| 1 | 0 | 1 | 0 | 1 |
| 1 | 0 | 0 | 1 | 1 |
| 1 | 0 | 0 | 0 | 0 |
| 0 | 1 | 1 | 1 | 1 |
| 0 | 1 | 1 | 0 | 1 |
| 0 | 1 | 0 | 1 | 1 |
| 0 | 1 | 0 | 0 | 1 |
| 0 | 0 | 1 | 1 | 1 |
| 0 | 0 | 1 | 0 | 1 |
| 0 | 0 | 0 | 1 | 1 |
| 0 | 0 | 0 | 0 | 1 |

1. Draw the Karnaugh map (3 pts).

2. By any means of your own choosing (aside from asking your neighbor, checking the book, calling a lifeline, etc.), minimize the truth function (that is, find a neat and tidy Boolean expression).

Problem 11. Minimize the finite state machine given by the following graph:

