

## Math Circles: Graph Theory

Below are several floor plans for houses. A group of friends has decided to visit each other's houses. The host's goal is to show his or her house as efficiently as possible.

Ideally, he or she wants to start from the front door, **go through each door of the house once**, and end up at the front door again.

Alternatively, the host also doesn't mind if the guest start from the front door, **go through each door of the house once**, and end up in some final room.

For each of the houses below, determine if either situation is possible (you can decide which door is the front door).

- Hint: You may end up outside. That's okay, just walk back to the front.

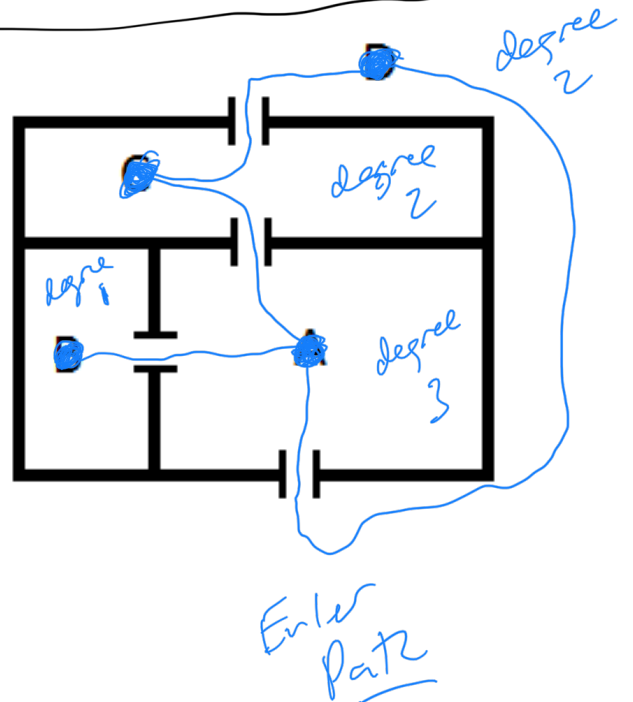
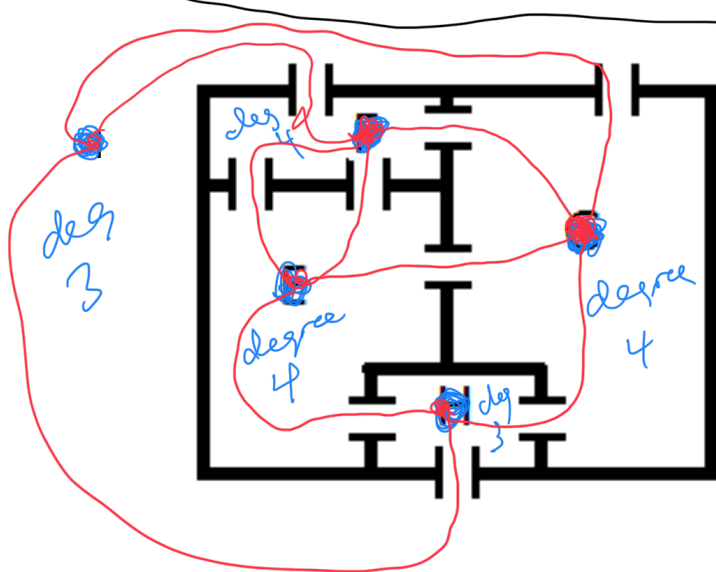
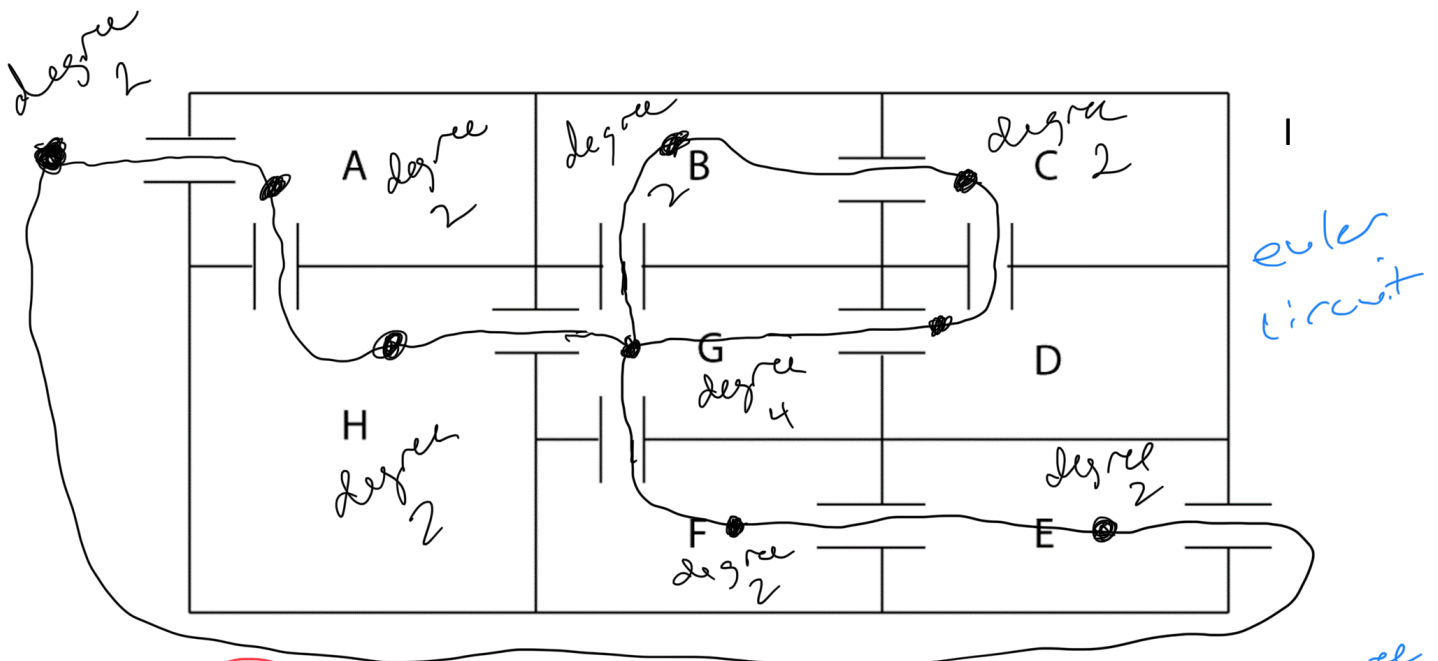

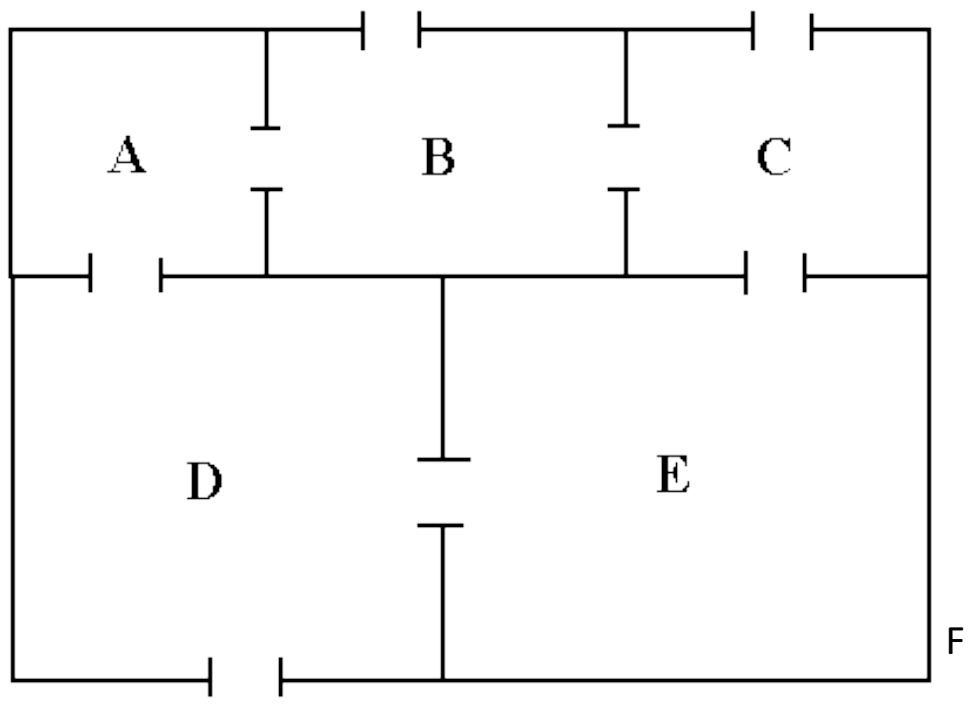
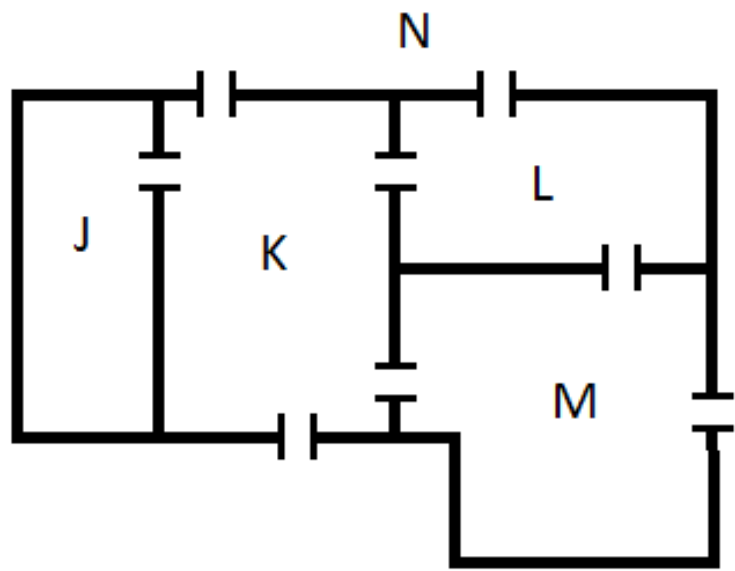

A face (or region) is an area bounded by edges in a graph.

**New Definition:** A path is a sequence of vertices connected by adjacent edges. More practically, you form a path by tracing over edges in the graph.

**New Definition:** A graph has an *Euler Path* if there is a path starting at one vertex and ending at another that uses each edge exactly once.

**New Definition:** A graph has an *Euler Circuit* if there is a path starting and ending at the same vertex that uses each edge exactly once.

1. For each of the 5 houses, determine whether or not they have an Euler Path or Circuit.

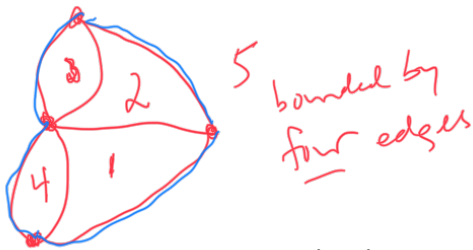

2. Count the degree of each vertex for each of the 5 houses. Is there an optimal vertex to start at based on the degree of the vertex?

3. Determine whether these graphs have Euler Paths or Euler Circuits

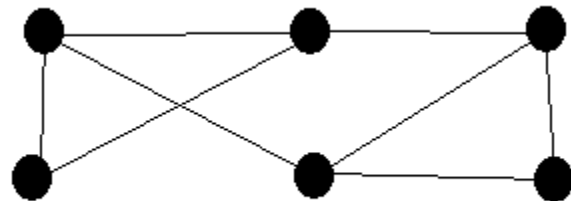
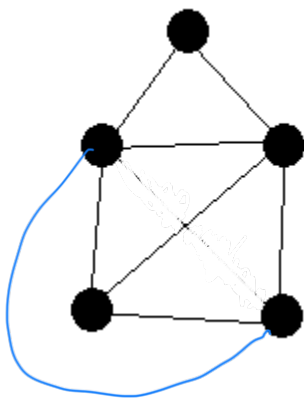

F-5  
E-8  
V-5

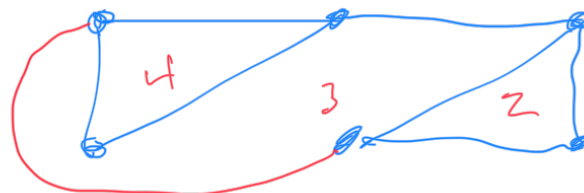
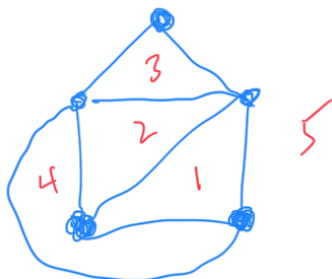

F-4  
E-8  
V-6

$$5 - 8 + 5 = \underline{\underline{2}}$$

$$6 - 8 + 4 = \underline{\underline{2}}$$

**Euler's Formula:** The number of vertices, edges, and faces are determined by Euler's Formula. Compute the following equation for each of your graphs:

Do you always get the same answer?

$$V - E + F = 2$$

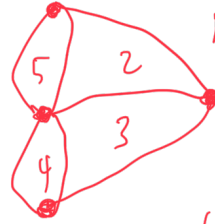

$$F = 5$$
$$E = 7$$
$$V = 4$$

$$4 - 7 + 5 = 2$$

Use Euler's Formula to figure out the missing information and draw a graph for each one.

1.  $F = 2, E = 4$

2.  $V = 6, F = 3$

3.  $E = 2, V = 3$